



3

PLACCHETTE
TIPS

DI



FORATURA
DRILLING



TUTTI GLI USI
ALL THE
APPLICATIONS



GREZZO
ROUGH



WN090
WH2
G1P

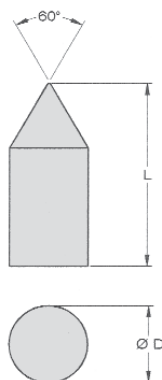

CODICE CODE	DIMENSIONI - DIMENSIONS (mm)	
	ØD	L
D/0	5,0	12,0
D/1.2	7,0	14,0
D/3	11,0	20,0
D/4	14,0	22,0
D/5.6	18,0	30,0

UI



FORATURA
DRILLING



TUTTI GLI USI
ALL THE
APPLICATIONS



GREZZO
ROUGH



WH2
WN090
G1P

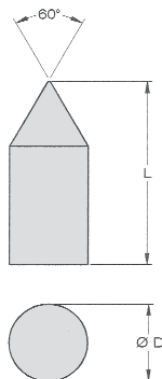

CODICE CODE	DIMENSIONI - DIMENSIONS (mm)	
	ØD	L
U/0	6,0	12,0
U/1.2	8,0	15,0
U/3	12,0	25,0
U/4	15,0	25,0
U/5	18,0	28,0
U/6	21,0	35,0

WXRC



FORATURA
DRILLING



TUTTI GLI USI
ALL THE
APPLICATIONS



GREZZO
ROUGH



WH2
WN090
G1P

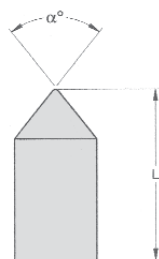

PLACCHETTE PER PIETRA
STONE TIPS

CODICE CODE	DIMENSIONI - DIMENSIONS (mm)			
	ØD	L	α°	L. max
WXRC - 7 - 014	2,5	8,0	90°	10,0
WXRC - 7 - 015	2,5	8,0	50°	10,0
WXRC - 7 - 008	3,0	14,0	50°	14,0
WXRC - 7 - 016	3,5	10,0	90°	11,0
WXRC - 7 - 003	4,0	11,0	77°	19,0
WXRC - 7 - 004	4,0	12,0	82°	19,0
WXRC - 7 - 011	4,0	4,0	80°	10,0
WXRC - 7 - 005	5,0	12,0	82°	19,0
WXRC - 7 - 006	5,0	13,0	60°	19,0
WXRC - 7 - 002	6,0	13,0	77°	19,0
WXRC - 7 - 017	6,0	6,0	90°	6,0
WXRC - 7 - 007	6,0	13,0	60°	19,0
WXRC - 7 - 001	7,0	15,0	76°	18,0
WXRC - 7 - 009	7,0	18,0	100°	18,0
WXRC - 7 - 010	8,0	8,0	80°	10,0
WXRC - 7 - 012	10,0	21,0	90°	24,0
WXRC - 7 - 013	10,0	21,0	120°	24,0

WXRC



FORATURA
DRILLING



PIETRA
STONE



GREZZO
ROUGH



WH2
WN090
G1P

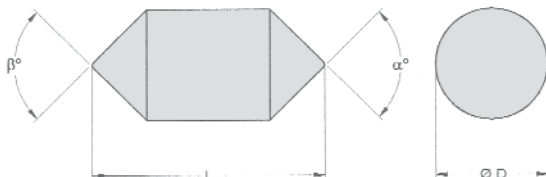

CODICE CODE	DIMENSIONI - DIMENSIONS (mm)				
	ØD	L	α°	β°	L. max
WXRC - 9 - 001	7,0	18,0	100°	100°	18,0
WXRC - 9 - 002	10,0	21,0	90°	90°	24,0
WXRC - 9 - 003	10,0	21,0	90°	120°	24,0

WXRC



FORATURA
DRILLING



PIETRA
STONE



GREZZO
ROUGH



WH2
WN090
G1P

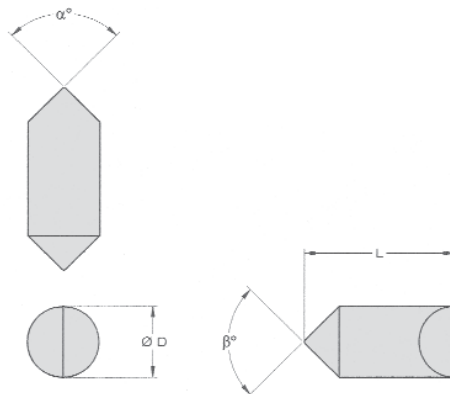

CODICE CODE	DIMENSIONI - DIMENSIONS (mm)				
	ØD	L	α°	β°	L. max
WXRC - 12 - 001	10,0	21,0	90°	90°	24,0
WXRC - 12 - 002	10,0	21,0	90°	120°	24,0

PLACCHETTE PER PIETRA
STONE TIPS

WXRC



FORATURA
DRILLING



PIETRA
STONE



GREZZO
ROUGH



WH2
WN090
G1P



CODICE CODE	DIMENSIONI - DIMENSIONS (mm)				
	ØD	L	α°	T	L. max
WXRC - 10 - 001	5,0	17,0	47°	0,5	19,0

WXRC



FORATURA
DRILLING



PIETRA
STONE



GREZZO
ROUGH



WH2
WN090
G1P

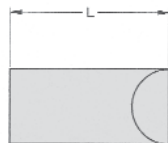
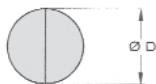
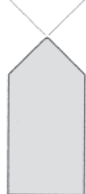
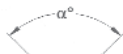

CODICE CODE	DIMENSIONI - DIMENSIONS (mm)				
	ØD	L	α°	T	L. max
WXRC - 11 - 001	10,0	21,0	90°		24,0

WXRC



FORATURA
DRILLING



PIETRA
STONE



GREZZO
ROUGH

WH2
WN090
G1P

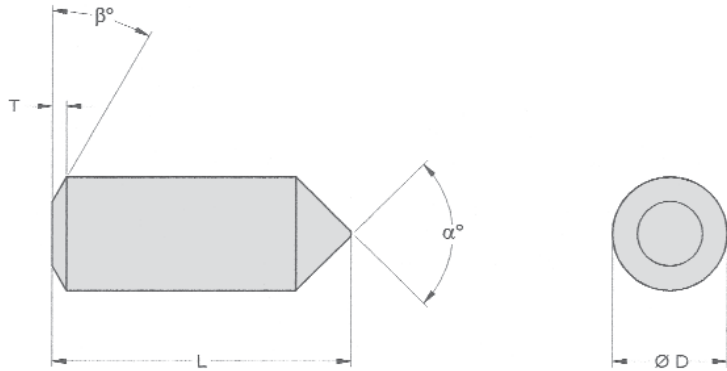

**CODICE
CODE**

DIMENSIONI - DIMENSIONS (mm)

	ØD	L	α°	β°	T	L. max
WXRC - 8 - 001	4,0	12,0	82°	30°	0,5	19,0
WXRC - 8 - 002	5,0	12,0	82°	30°	0,5	19,0
WXRC - 8 - 005	7,0	15,0	100°	45°	0,5	18,0
WXRC - 8 - 003	8,0	21,0	90°	30°	1,0	24,0
WXRC - 8 - 004	9,0	21,0	90°	30°	1,0	21,0

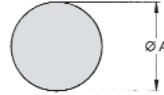
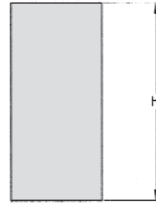

PLACCHETTE PER PIETRA
STONE TIPS

WXRFFRESATURA
MILLINGTUTTI GLI USI
ALL THE
APPLICATIONSGREZZO
ROUGHWH2
WN090
G1P**CODICE
CODE****DIMENSIONI - DIMENSIONS (mm)**

CODICE CODE	DIMENSIONI - DIMENSIONS (mm)	
	ØA	H
WXRF - 0 - 001	4,3	10,0
WXRF - 0 - 002	5,3	12,0
WXRF - 0 - 003	6,3	14,0
WXRF - 0 - 004	8,3	18,0
WXRF - 0 - 005	10,4	20,0
WXRF - 0 - 006	12,4	25,0
WXRF - 0 - 007	16,5	25,0
WXRF - 0 - 008	20,5	25,0

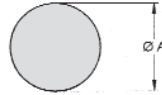
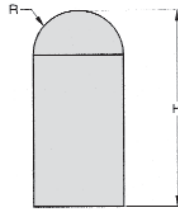
WXRFFRESATURA
MILLINGTUTTI GLI USI
ALL THE
APPLICATIONSGREZZO
ROUGHWH2
WN090
G1P

CODICE CODE	DIMENSIONI - DIMENSIONS (mm)		
	ØA	H	R
WXRF - 1 - 001	3,8	10,0	1,90
WXRF - 1 - 002	4,3	10,0	2,15
WXRF - 1 - 003	5,3	12,0	2,65
WXRF - 1 - 004	6,3	14,0	3,15
WXRF - 1 - 007	8,3	18,0	4,15
WXRF - 1 - 008	10,4	20,0	5,20
WXRF - 1 - 009	12,4	25,0	6,20
WXRF - 1 - 010	16,5	25,0	8,25
WXRF - 1 - 011	20,5	25,0	10,25

PLACCHETTE PER PIETRA
STONE TIPS

WXP - 0253/...



FORATURA
DRILLING



PIETRA
STONE



GREZZO
ROUGH



G1P
WH2
WH15

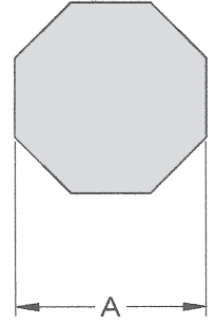
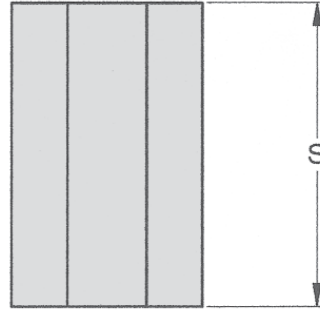

CODICE CODE	DIMENSIONI - DIMENSIONS (mm)		
	A	S	S. max
WXP - 0253	5,0	16,0	18,0
WXP - 0135	5,5	16,0	18,0
WXP - 0266	6,0	16,0	18,0
WXP - 0127	6,4	16,0	18,0
WXP - 0254	7,0	16,0	18,0
WXP - 0128	7,5	16,0	18,0
WXP - 0235	10,0	16,0	18,0



WXP - 1253/...



FORATURA
DRILLING



PIETRA
STONE



GREZZO
ROUGH



GIP
WH2
WH15

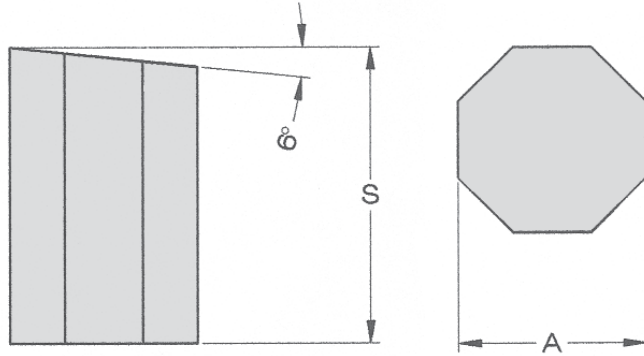

CODICE CODE	DIMENSIONI - DIMENSIONS (mm)		
	A	S	S. max
WXP - 1253	5,0	16,0	18,0
WXP - 1135	5,5	16,0	18,0
WXP - 1266	6,0	16,0	18,0
WXP - 1127	6,4	16,0	18,0
WXP - 1254	7,0	16,0	18,0
WXP - 1128	7,5	16,0	18,0
WXP - 1235	10,0	16,0	18,0

PLACCHETTE PER PIETRA
STONE TIPS

WXP - 0284



FORATURA
DRILLING



PIETRA
STONE



GREZZO
ROUGH



G1P
WH2
WH15

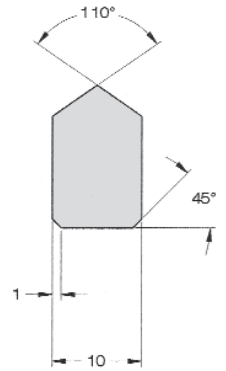
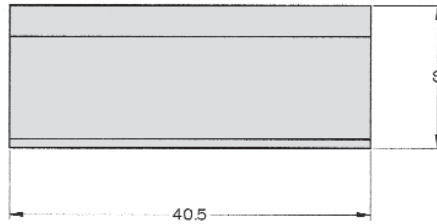

**CODICE
CODE**

DIMENSIONI - DIMENSIONS (mm)

S

S. max

WXP - 0284

16,0

19,0

WXP - 0285



FORATURA
DRILLING



PIETRA
STONE



GREZZO
ROUGH



G1P
WH2
WH15

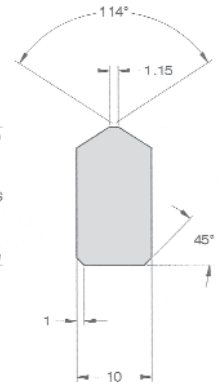
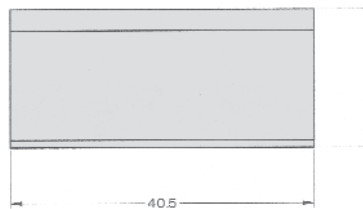

**CODICE
CODE**

DIMENSIONI - DIMENSIONS (mm)

S

S. max

WXP - 0285

18,5

19,0

PLACCHETTE PER PIETRA
STONE TIPS

WXP - 0012



FORATURA
DRILLING



PIETRA
STONE



GREZZO
ROUGH



G1P
WH2
WH15

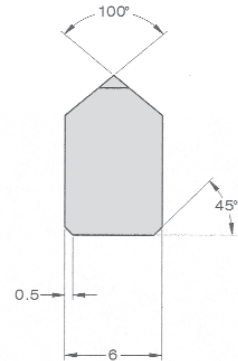
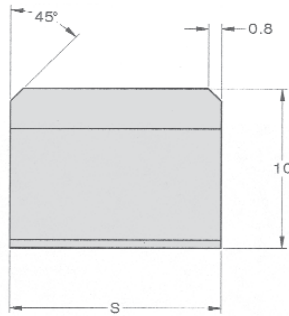

**CODICE
CODE**

DIMENSIONI - DIMENSIONS (mm)

S

S. max

WXP - 0012

13,0

14,0

WXP - 0301/...



FORATURA
DRILLING



PIETRA
STONE



GREZZO
ROUGH



G1P
WH2
WH15

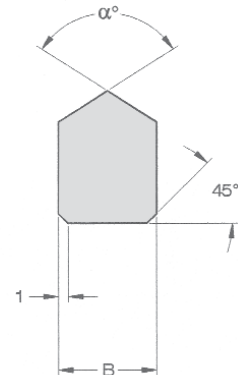
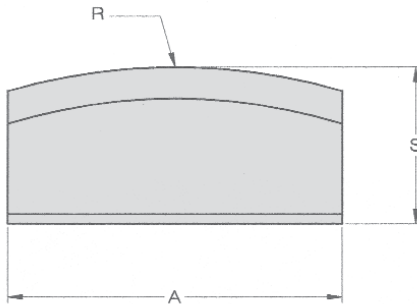

**CODICE
CODE**

DIMENSIONI - DIMENSIONS (mm)

A

B

R

α°

S

S. max

WXP - 0301

34,0

10,0

60,0

115°

16,0

19,0

WXP - 0286

39,5

10,0

70,0

110°

18,0

19,0

WXP - 0118

41,0

9,0

120,0

115°

16,0

17,0

PLACCHETTE PER PIETRA
STONE TIPS

WXP - 0071

-  FORATURA
DRILLING
-  PIETRA
STONE
-  GREZZO
ROUGH
- 

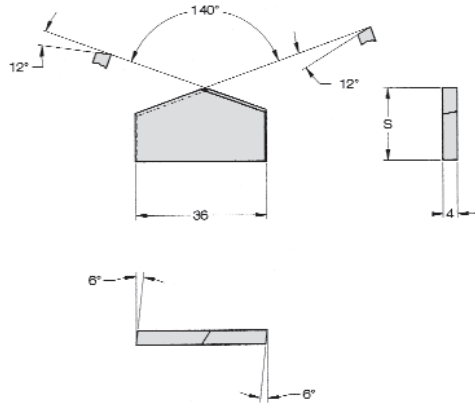

G1P
WH2
WH15

CODICE CODE	DIMENSIONI - DIMENSIONS (mm)	
	S	S. max
WXP - 0071	20,0	22,0

WXPT ...

-  FORATURA
DRILLING
-  PIETRA
STONE
-  GREZZO
ROUGH
- 

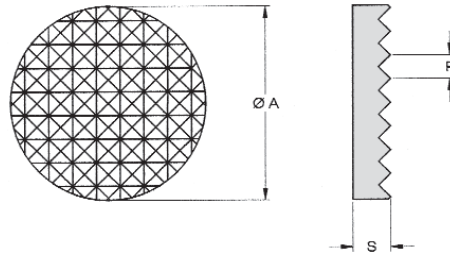

G1P
WH2
WH15

CODICE CODE	DIMENSIONI - DIMENSIONS (mm)			
	ØA	P	S	S. max
WXPT - 1 - 001	9,1	2,0	3,18	11,0
WXPT - 1 - 002	12,7	2,0	3,18	7,0
WXPT - 1 - 003	16,4	2,0	3,18	9,0
WXPT - 2 - 001	9,2	3,1	3,18	10,0
WXPT - 2 - 002	12,5	3,1	3,18	10,0

WXP-0326



FORATURA
DRILLING



PIETRA
STONE



GREZZO
ROUGH



G1P
WH2
WH15

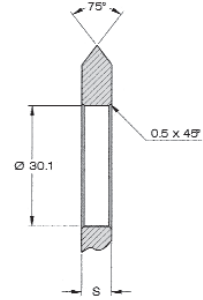
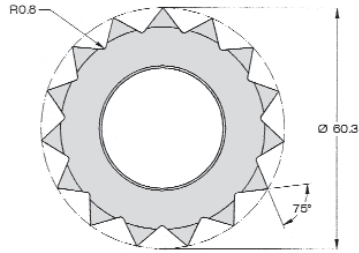

**CODICE
CODE**

DIMENSIONI - DIMENSIONS (mm)

CODICE CODE	DIMENSIONI - DIMENSIONS (mm)		
	S	n° denti	S. max
WXP-0326	7,0	15,0	10,0

WXP-0298



FORATURA
DRILLING



PIETRA
STONE



GREZZO
ROUGH



G1P
WH2
WH15

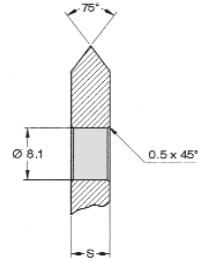
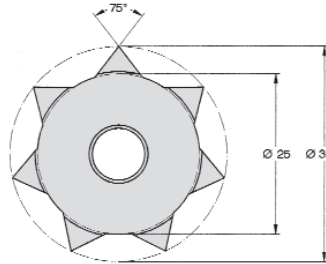

**CODICE
CODE**

DIMENSIONI - DIMENSIONS (mm)

CODICE CODE	DIMENSIONI - DIMENSIONS (mm)		
	S	n° denti	S. max
WXP-0298	6,0	7	8,0

WXP-0299



FORATURA
DRILLING



PIETRA
STONE



GREZZO
ROUGH



G1P
WH2
WH15

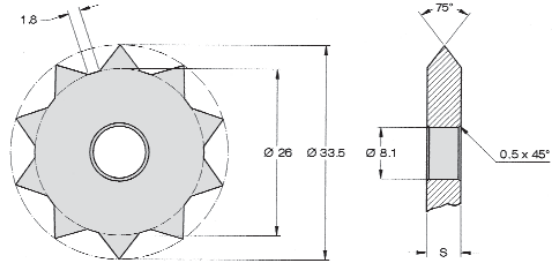

**CODICE
CODE**

DIMENSIONI - DIMENSIONS (mm)

	S	n° denti	S. max
WXP-0299	6,0	10	8,0

WXP-0221



FORATURA
DRILLING



PIETRA
STONE



GREZZO
ROUGH



G1P
WH2
WH15

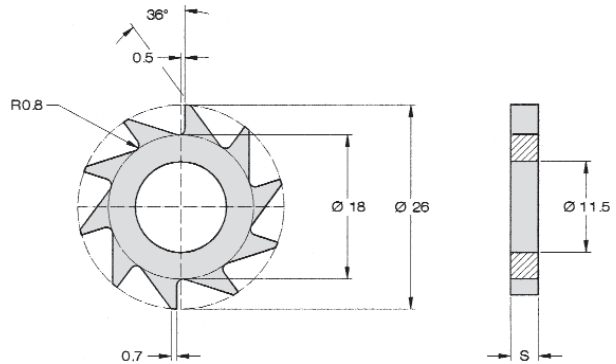

**CODICE
CODE**

DIMENSIONI - DIMENSIONS (mm)

	S	n° denti	S. max
WXP-0221	3,5	10	6,0

WXP-0302



FORATURA
DRILLING



PIETRA
STONE



GREZZO
ROUGH



G1P
WH2
WH15

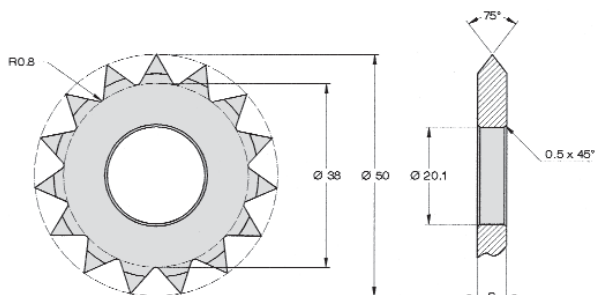

CODICE
CODE

DIMENSIONI - DIMENSIONS (mm)

CODICE CODE	DIMENSIONI - DIMENSIONS (mm)		
	S	n° denti	S. max
WXP-0302	6,0	15	8,0

SNMA 120504-T



FORATURA
DRILLING

WH1



PIETRA
STONE



GREZZO
ROUGH

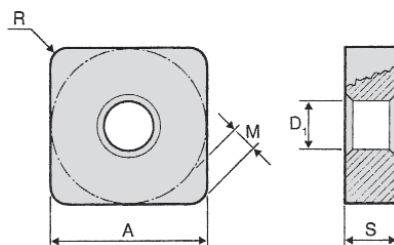

Per taglio marmo
For marble cutting

CODICE
CODE

DIMENSIONI - DIMENSIONS (mm)

CODICE CODE	DIMENSIONI - DIMENSIONS (mm)				
	A	D1	S	R	M
SNMA120504-T	12,70	5,16	5,60	0,4	2,466