



4

COLTELLINI
CUTTING KNIVES

WP1FC



FRESATURA
MILLING



LEGNO
WOOD



RETTIFICATO
GROUND



WH15

WH01

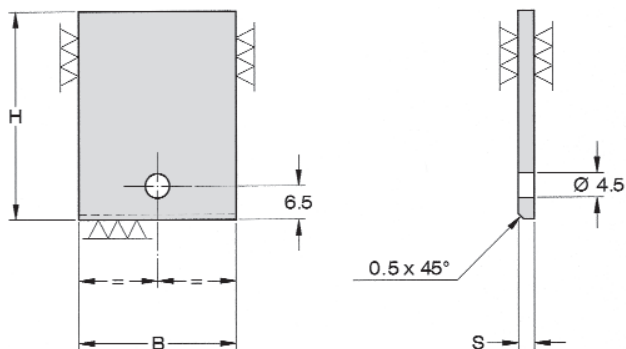

CODICE CODE	DIMENSIONI - DIMENSIONS (mm)		
	B	H	S
WP1FC1	15	15	2
WP1FC2	15	20	2
WP1FC3	15	25	2
WP1FC4	15	30	2
WP1FC23	16	20	2
WP1FC5	20	20	2
WP1FC6	20	25	2
WP1FC7	20	30	2
WP1FC8	20	35	2
WP1FC9	25	20	2
WP1FC10	25	25	2
WP1FC11	25	30	2
WP1FC12	25	35	2
WP1FC13	30	20	2
WP1FC14	30	25	2
WP1FC15	30	30	2
WP1FC16	30	35	2
WP1FC17	30	40	2
WP1FC18	35	20	2
WP1FC19	35	25	2
WP1FC20	35	30	2
WP1FC21	35	35	2
WP1FC22	35	40	2

WP1FD



FRESATURA
MILLING



LEGNO
WOOD



RETTIFICATO
GROUND



WH15

WH01

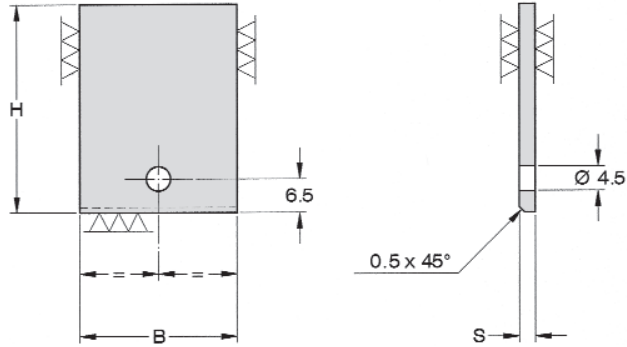

**CODICE
CODE**

DIMENSIONI - DIMENSIONS (mm)

	B	H	S
WP1FD1	20	35	3
WP1FD2	30	30	3
WP1FD3	30	35	3
WP1FD4	30	40	3
WP1FD5	35	30	3
WP1FD6	35	35	3
WP1FD7	35	40	3



WP2FC



FRESATURA
MILLING



LEGNO
WOOD



RETTIFICATO
GROUND



WH15

WH01

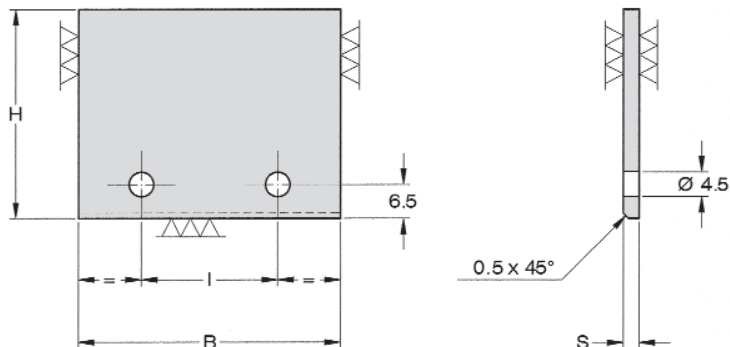

CODICE CODE	DIMENSIONI - DIMENSIONS (mm)			
	B	H	I	S
WP2FC1	30	20	14	2
WP2FC2	30	25	14	2
WP2FC3	30	30	14	2
WP2FC4	30	35	14	2
WP2FC5	30	40	14	2
WP2FC28	35	20	14	2
WP2FC6	35	25	14	2
WP2FC7	35	30	14	2
WP2FC8	35	35	14	2
WP2FC9	35	40	14	2
WP2FC10	40	20	26	2
WP2FC11	40	25	26	2
WP2FC13	40	30	26	2
WP2FC14	40	35	26	2
WP2FC15	40	40	26	2
WP2FC12	40	45	26	2
WP2FC16	50	20	26	2
WP2FC17	50	25	26	2
WP2FC18	50	30	26	2
WP2FC19	50	35	26	2
WP2FC20	50	40	26	2
WP2FC21	60	20	26	2
WP2FC22	60	30	26	2
WP2FC23	60	35	26	2
WP2FC24	60	40	26	2

CODICE CODE	DIMENSIONI - DIMENSIONS (mm)			
	B	H	I	S
WP2FC29	80	20	26	2
WP2FC30	80	25	26	2
WP2FC25	80	30	26	2
WP2FC26	80	35	26	2
WP2FC27	80	40	26	2

WP2FD



WH15
WHO1

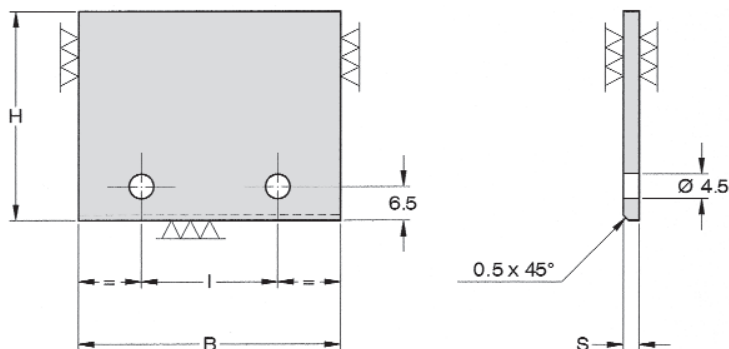

CODICE CODE	DIMENSIONI - DIMENSIONS (mm)			
	B	H	I	S
WP2FD1	40	30	26	3
WP2FD2	40	35	26	3
WP2FD3	40	40	26	3
WP2FD4	60	30	26	3
WP2FD5	60	35	26	3
WP2FD6	60	40	26	3
WP2FD20	80	20	26	3
WP2FD7	80	30	26	3
WP2FD8	80	35	26	3
WP2FD9	80	40	26	3

WP1F



FRESATURA
MILLING



LEGNO
WOOD



RETTIFICATO
GROUND



WH15

WH01

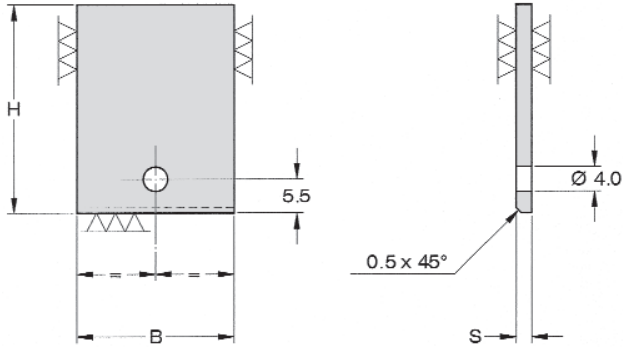

**CODICE
CODE**

DIMENSIONI - DIMENSIONS (mm)

B

H

S

WP1F1

26

25

2

WP1FL ...



FRESATURA
MILLING



LEGNO
WOOD



RETTIFICATO
GROUND



WH15

WH01

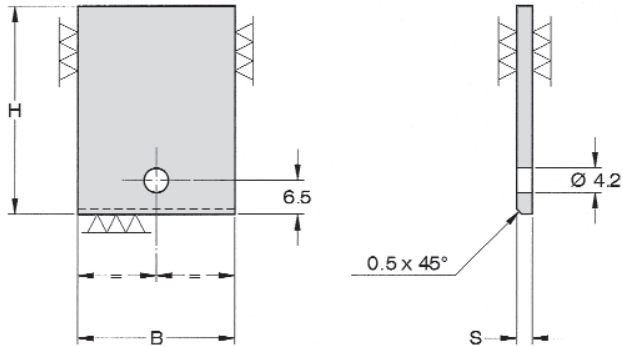

**CODICE
CODE**

DIMENSIONI - DIMENSIONS (mm)

B

H

S

WP1FL3

20

26

2

WP1FL4

25

31

2

WP1FL ...



WH15
WH01

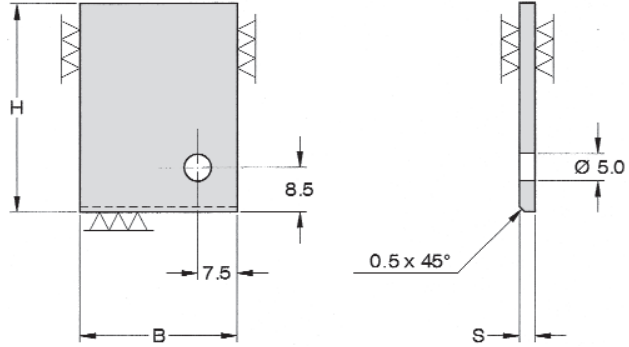

CODICE CODE	DIMENSIONI - DIMENSIONS (mm)		
	B	H	S
WP1FL5	25	31	2
WP1FL6	27	31	2

WP1F ...



WH15
WH01

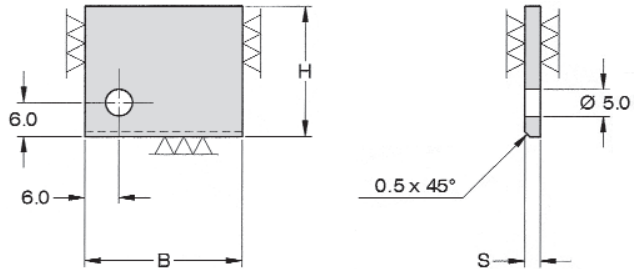

CODICE CODE	DIMENSIONI - DIMENSIONS (mm)		
	B	H	S
WP1F2	25,5	20	2

WP1F ...



FRESATURA
MILLING



LEGNO
WOOD



RETTIFICATO
GROUND



WH15

WH01

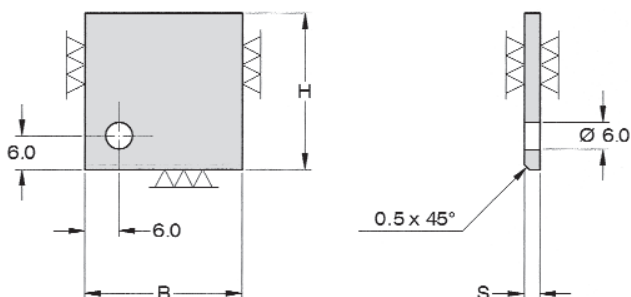

CODICE CODE	DIMENSIONI - DIMENSIONS (mm)		
	B	H	S
WP1F3	28	13	2,5
WP1F4	28	19	2,5
WP1F5	28	28	2,5

WP1FL ...



FRESATURA
MILLING



LEGNO
WOOD



RETTIFICATO
GROUND



WH15

WH01

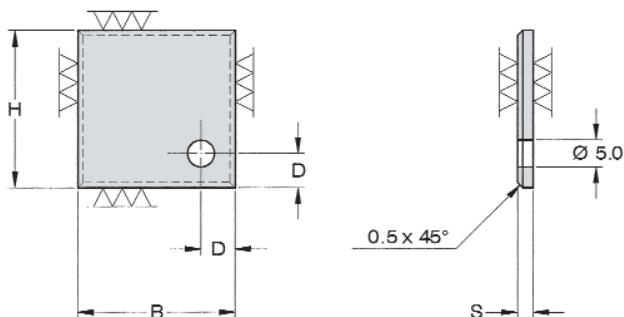

CODICE CODE	DIMENSIONI - DIMENSIONS (mm)			
	B	H	D	S
WP1FL1	20,5	20,5	5	2
WP1FL2	25,5	25,5	6	2

WP2FL ...



WH15
WH01

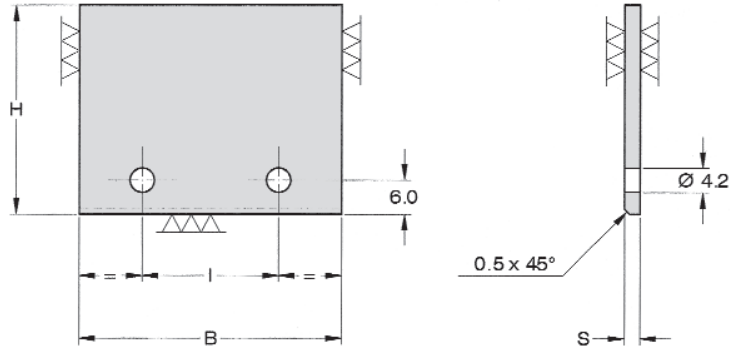

CODICE CODE	DIMENSIONI - DIMENSIONS (mm)			
	B	H	I	S
WP2FL10	30	30	14	2
WP2FL11	50	27	26	2

WP2F ...



WH15
WH01

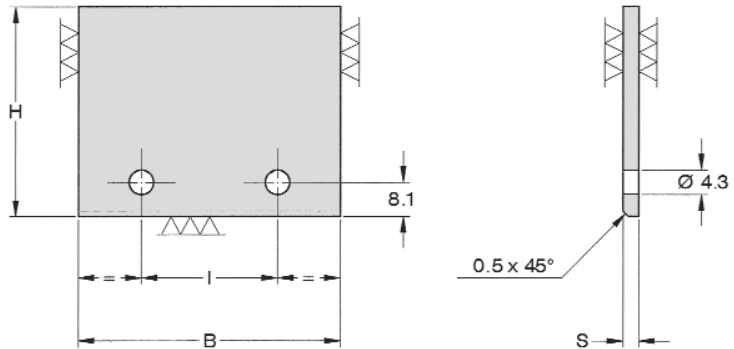

CODICE CODE	DIMENSIONI - DIMENSIONS (mm)			
	B	H	I	S
WP2F1	41	35	19,7	3

WP2FL ...



FRESATURA
MILLING



LEGNO
WOOD



RETTIFICATO
GROUND

WH15

WH01

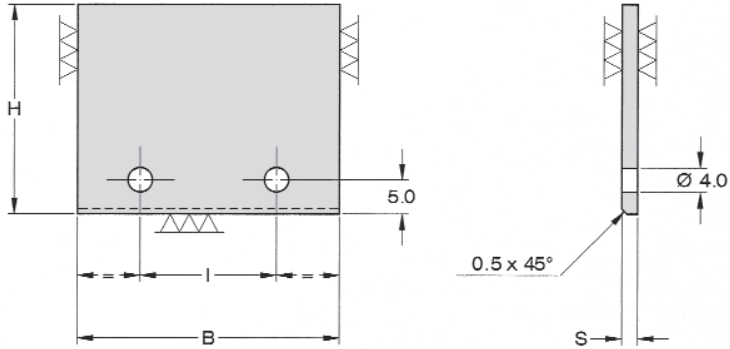

**CODICE
CODE**

DIMENSIONI - DIMENSIONS (mm)

WP2FL9

B	H	I	S
40	16	15	2

WP2FL ...



FRESATURA
MILLING



LEGNO
WOOD



RETTIFICATO
GROUND

WH15

WH01

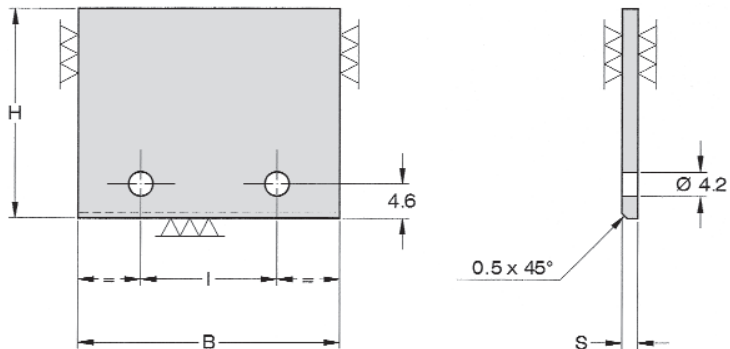

**CODICE
CODE**

DIMENSIONI - DIMENSIONS (mm)

WP2FL1

B	H	I	S
30	27	19	2
30	40	19	2
35	27	19	2
40	27	19	2
40	40	19	2
40	27	28	2
50	27	26	2
60	40	26	2

WP2FL2

WP2FL3

WP2FL4

WP2FL5

WP2FL6

WP2FL7

WP2FL8

WP2F ...

-  FRESATURA
MILLING
-  LEGNO
WOOD
-  RETTIFICATO
GROUND
- 

WH15
WH01

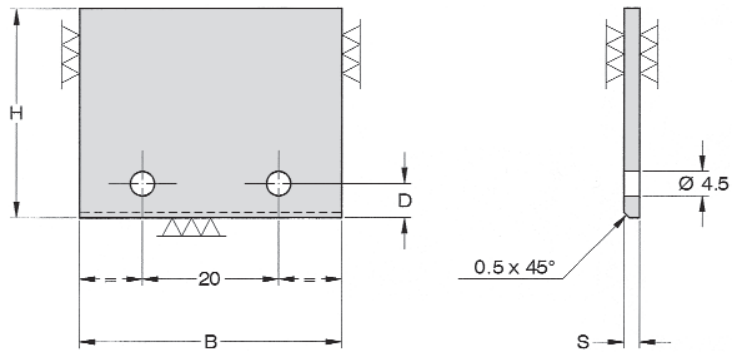

CODICE CODE	DIMENSIONI - DIMENSIONS (mm)			
	B	H	D	S
WP2F3	42	23	4,8	2
WP2F4	42	33	5,2	2

WP2F ...

-  FRESATURA
MILLING
-  LEGNO
WOOD
-  RETTIFICATO
GROUND
- 

WH15
WH01

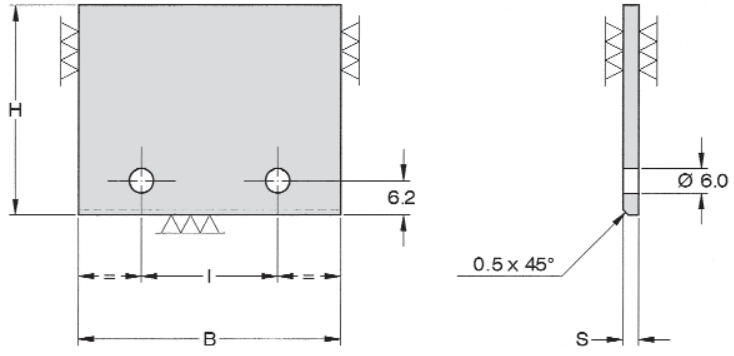

CODICE CODE	DIMENSIONI - DIMENSIONS (mm)			
	B	H	I	S
WP2F2	58	23	22,7	3

WP2F ...



FRESATURA
MILLING



LEGNO
WOOD



RETTIFICATO
GROUND

WH15

WH01

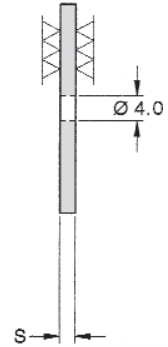
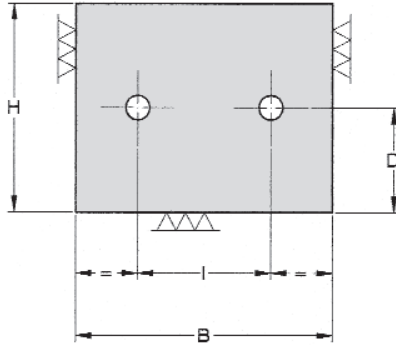

**CODICE
CODE**

DIMENSIONI - DIMENSIONS (mm)

WP2FC50

B	H	I	D	S
45	35	26	17,5	2

WP2F ...



FRESATURA
MILLING



LEGNO
WOOD



RETTIFICATO
GROUND

WH15

WH01

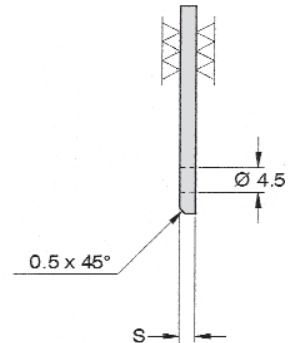
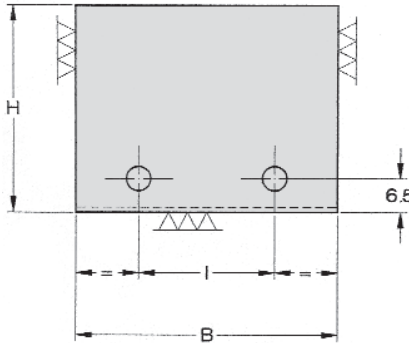

**CODICE
CODE**

DIMENSIONI - DIMENSIONS (mm)

WP2FC70

B	H	I	S
30	30	19	2



WH15
WH01

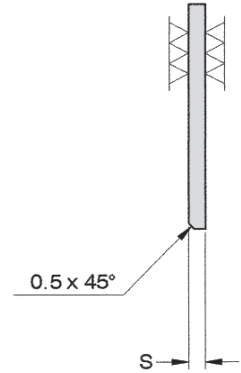
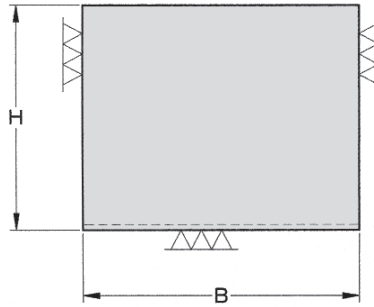

CODICE CODE	DIMENSIONI - DIMENSIONS (mm)		
	B	H	S
WP151520	15,0	15,5	2,0
WP152020	15,0	20,5	2,0
WP202020	20,0	20,5	2,0
WP202520	20,0	25,5	2,0
WP203020	20,0	30,5	2,0
WP203520	20,0	35,5	2,0
WP252020	25,0	20,5	2,0
WP252520	25,0	25,5	2,0
WP253020	25,0	30,5	2,0
WP253520	25,0	35,5	2,0
WP302020	30,0	20,5	2,0
WP302520	30,0	25,5	2,0
WP303020	30,0	30,5	2,0
WP303520	30,0	35,5	2,0
WP304020	30,0	40,5	2,0
WP352020	35,0	20,5	2,0
WP352520	35,0	25,5	2,0
WP353520	35,0	35,5	2,0
WP354020	35,0	40,5	2,0
WP402020	40,0	20,5	2,0
WP402520	40,0	25,5	2,0
WP403020	40,0	30,5	2,0
WP403520	40,0	35,5	2,0
WP404020	40,0	40,5	2,0
WP453020	45,0	30,5	2,0
WP453520	45,0	35,5	2,0
WP502020	50,0	20,5	2,0

CODICE CODE	DIMENSIONI - DIMENSIONS (mm)		
	B	H	S
WP502520	50,0	25,5	2,0
WP503020	50,0	30,5	2,0
WP504020	50,0	40,5	2,0
WP504520	50,0	45,5	2,0
WP602020	60,0	20,5	2,0
WP602520	60,0	25,5	2,0
WP603020	60,0	30,5	2,0
WP603520	60,0	35,5	2,0
WP604020	60,0	40,5	2,0
WP802525	80,0	25,5	2,5
WP803525	80,0	35,5	2,5
WP804525	80,0	45,5	2,5



COLTELLINI
CUTTING KNIVES

WP1FB ...



FRESATURA
MILLING



LEGNO
WOOD



RETTIFICATO
GROUND

WH15

WH01

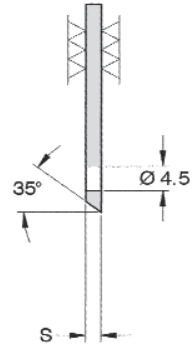
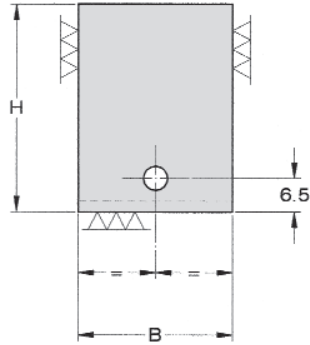

CODICE CODE	DIMENSIONI - DIMENSIONS (mm)		
	B	H	S
WP1FB1	15	15	2
WP1FB2	15	20	2
WP1FB3	15	25	2
WP1FB4	15	30	2
WP1FB23	16	20	2
WP1FB5	20	20	2
WP1FB6	20	25	2
WP1FB7	20	30	2
WP1FB8	20	35	2
WP1FB9	25	20	2
WP1FB10	25	25	2
WP1FB11	25	30	2
WP1FB12	25	35	2
WP1FB13	30	20	2
WP1FB14	30	25	2
WP1FB15	30	30	2
WP1FB16	30	35	2
WP1FB17	30	40	2
WP1FB18	35	20	2
WP1FB19	35	25	2
WP1FB20	35	30	2
WP1FB21	35	35	2
WP1FB22	35	40	2

WP2FB ...



FRESATURA
MILLING



LEGNO
WOOD



RETTIFICATO
GROUND

WH15

WH01

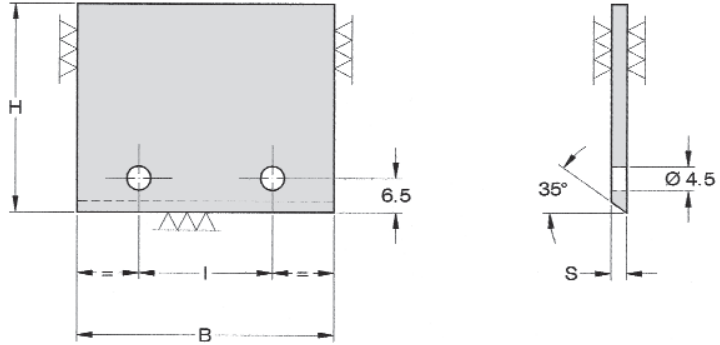

CODICE CODE	DIMENSIONI - DIMENSIONS (mm)			
	B	H	I	S
WP2FB1	30	20	14	2
WP2FB2	30	25	14	2
WP2FB3	30	30	14	2
WP2FB4	30	35	14	2
WP2FB5	30	40	14	2
WP2FB28	35	20	14	2
WP2FB6	35	25	14	2
WP2FB7	35	30	14	2
WP2FB8	35	35	14	2
WP2FB9	35	40	14	2
WP2FB10	40	20	26	2
WP2FB11	40	25	26	2
WP2FB13	40	30	26	2
WP2FB14	40	35	26	2
WP2FB15	40	40	26	2
WP2FB12	40	45	26	2
WP2FB16	50	20	26	2
WP2FB17	50	25	26	2
WP2FB18	50	30	26	2
WP2FB19	50	35	26	2
WP2FB20	50	40	26	2
WP2FB21	60	20	26	2
WP2FB22	60	30	26	2
WP2FB23	60	35	26	2
WP2FB24	60	40	26	2

CODICE CODE	DIMENSIONI - DIMENSIONS (mm)			
	B	H	I	S
WP2FB29	80	20	26	2
WP2FB30	80	25	26	2
WP2FB25	80	30	26	2
WP2FB26	80	35	26	2
WP2FB27	80	40	26	2

WXP 0330 G



FRESATURA
MILLING



LEGNO
WOOD



RETTIFICATO
GROUND

WH01

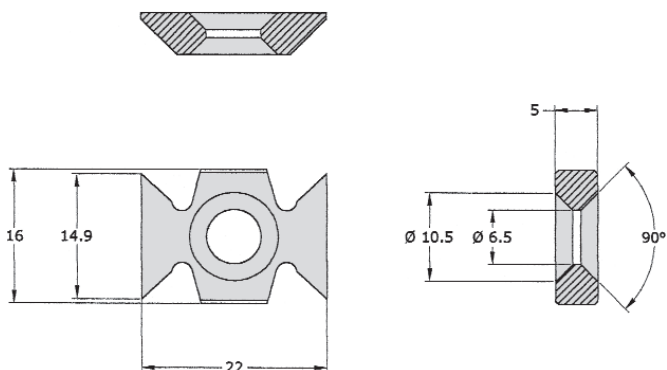

WXP 0330 R



FRESATURA
MILLING



LEGNO
WOOD



RETTIFICATO
GROUND

WH01

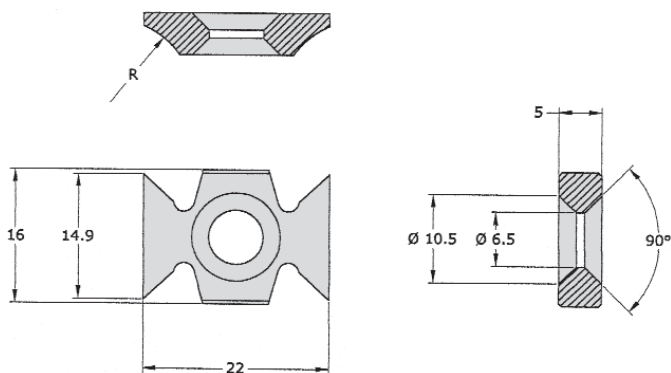

R

1,0	1,5	2,0	2,5	3,0	3,5	4,0	4,5	5,0
-----	-----	-----	-----	-----	-----	-----	-----	-----

WPS1215



FRESATURA
MILLING



LEGNO
WOOD



RETTIFICATO
GROUND



WH01

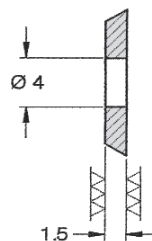
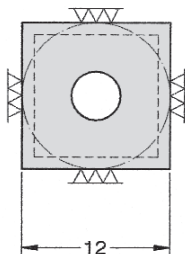
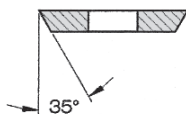

WPS14 ...



FRESATURA
MILLING



LEGNO
WOOD



RETTIFICATO
GROUND



WH01

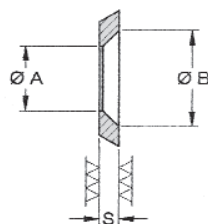
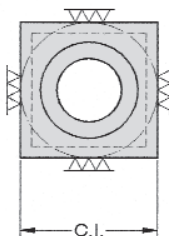
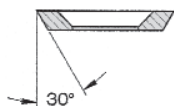

CODICE CODE	DIMENSIONI - DIMENSIONS (mm)			
	C.I.	S	ØA	ØB
WPS1412	14	1,2	8,7	10,2
WPS1420	14	2,0	6,7	10,0

WPT2220



FRESATURA
MILLING



LEGNO
WOOD



RETTIFICATO
GROUND



WH01

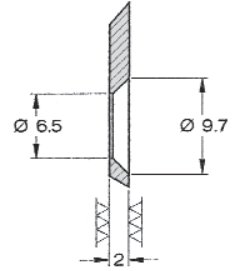
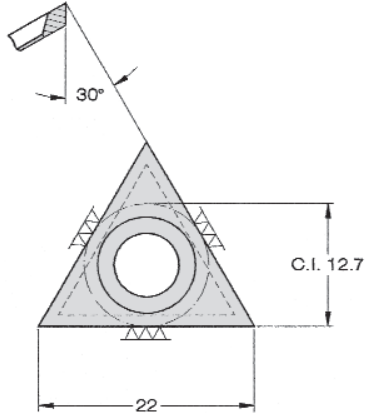

WPS1819



FRESATURA
MILLING



LEGNO
WOOD



RETTIFICATO
GROUND



WH01

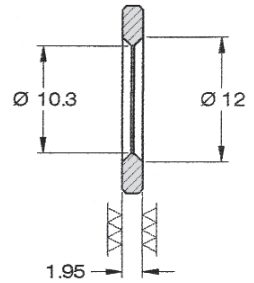
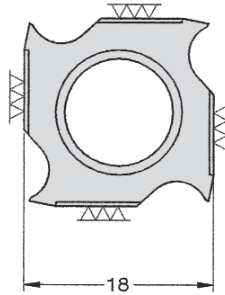

WP1F ...



FRESATURA
MILLING



LEGNO
WOOD



RETTIFICATO
GROUND

KZ08

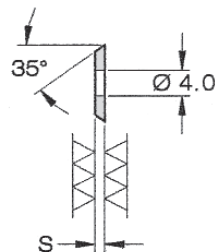
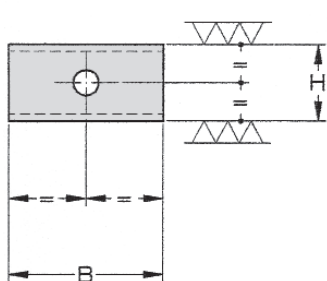

CODICE CODE	DIMENSIONI - DIMENSIONS (mm)		
	B	H	S
WP1FC007	7,65	12	1,5
WP1FC009	9	12	1,5
WP1FC015	15	12	1,5
WP1FC020	20	12	1,5

WP2F ...



FRESATURA
MILLING



LEGNO
WOOD



RETTIFICATO
GROUND

KZ08

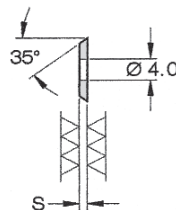
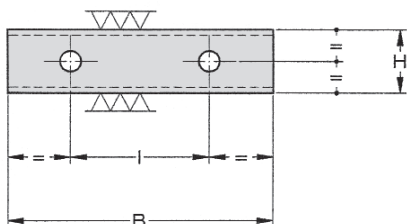

CODICE CODE	DIMENSIONI - DIMENSIONS (mm)			
	B	H	I	S
WP2FC030	30	12	14	1,5
WP2FC040	40	12	26	1,5
WP2FC050	50	12	26	1,5
WP2FC060	60	12	26	1,5

WXP - 0256

WH2

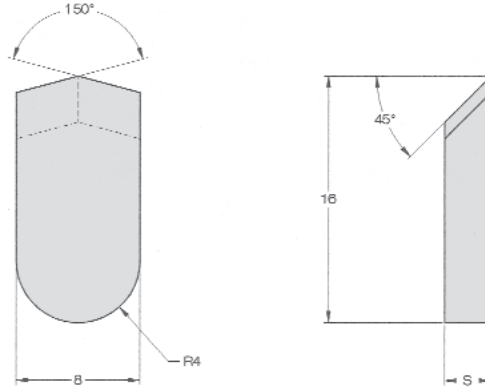

CODICE CODE	DIMENSIONI - DIMENSIONS(mm)	
	S	S. max
WXP - 0256	3,0	7,0

WXP - 0263

WH2
WN090

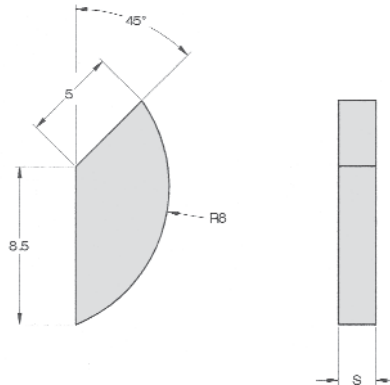

CODICE CODE	DIMENSIONI - DIMENSIONS(mm)	
	S	S. max
WXP - 0263	2,0	7,0

PLACCHETTE PER LEGNO
WOOD TIPS



FRESATURA
MILLING



LEGNO
WOOD



GREZZO
ROUGH



WH2
WN090

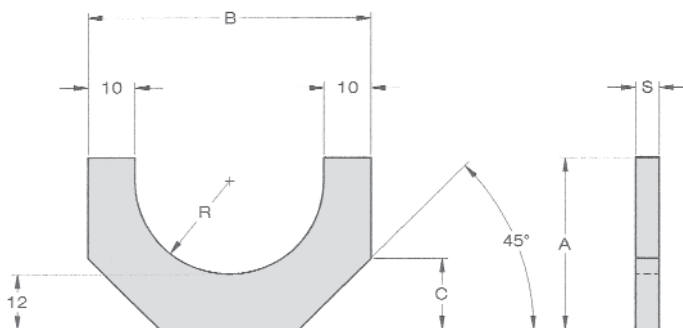

CODICE CODE	DIMENSIONI - DIMENSIONS(mm)				
	A	B	C	S	R
WXPL - 1 - 001	21,0	30,0	8,8	5,0	5,0
WXPL - 1 - 002	24,0	36,0	10,0	5,0	8,0
WXPL - 1 - 003	28,0	42,0	11,7	5,0	11,0
WXPL - 1 - 004	31,0	48,0	12,9	5,0	14,0
WXPL - 1 - 005	34,0	54,0	14,2	5,0	17,0
WXPL - 1 - 006	37,0	60,0	15,4	5,0	20,0
WXPL - 1 - 007	41,0	66,0	17,1	5,0	23,0
WXPL - 1 - 008	44,0	72,0	18,3	5,0	26,0
WXPL - 1 - 009	47,0	78,0	19,6	5,0	29,0
WXPL - 1 - 010	50,0	84,0	20,8	5,0	32,0
WXPL - 1 - 011	54,0	90,0	22,5	5,0	35,0
WXPL - 1 - 012	57,0	96,0	23,8	5,0	38,0
WXPL - 1 - 013	60,0	102,0	25,0	5,0	41,0
WXPL - 1 - 014	63,0	108,0	26,3	5,0	44,0
WXPL - 1 - 015	67,0	114,0	27,9	5,0	47,0
WXPL - 1 - 016	70,0	120,0	29,2	5,0	50,0

WXPL - 2 - ...



FRESATURA
MILLING



LEGNO
WOOD



GREZZO
ROUGH

WH2
WN090

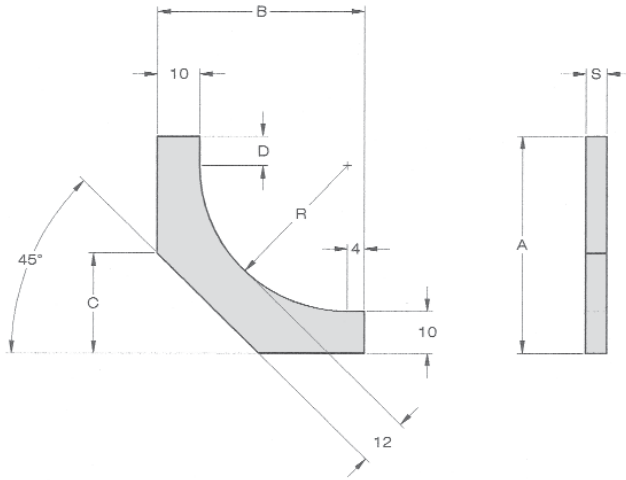

CODICE CODE	DIMENSIONI - DIMENSIONS(mm)					
	A	B	C	D	S	R
WXPL - 2 - 001	19,0	19,0	6,0	4,0	5,0	5,0
WXPL - 2 - 002	22,0	22,0	7,0	4,0	5,0	8,0
WXPL - 2 - 003	26,0	25,0	9,0	5,0	5,0	11,0
WXPL - 2 - 004	29,0	28,0	11,0	5,0	5,0	14,0
WXPL - 2 - 005	32,0	31,0	13,0	5,0	5,0	17,0
WXPL - 2 - 006	36,0	34,0	15,0	6,0	5,0	20,0
WXPL - 2 - 007	39,0	37,0	17,0	6,0	5,0	23,0
WXPL - 2 - 008	42,0	40,0	19,0	6,0	5,0	26,0
WXPL - 2 - 009	45,0	43,0	20,0	6,0	5,0	29,0
WXPL - 2 - 010	49,0	46,0	21,0	7,0	5,0	32,0
WXPL - 2 - 011	52,0	49,0	24,0	7,0	5,0	35,0
WXPL - 2 - 012	55,0	52,0	25,0	7,0	5,0	38,0
WXPL - 2 - 013	58,0	55,0	26,0	7,0	5,0	41,0

PLACCHETTE PER LEGNO
WOOD TIPS

WXP - ...

 FRESATURA
MILLING

 LEGNO
WOOD

 GREZZO
ROUGH



WH2

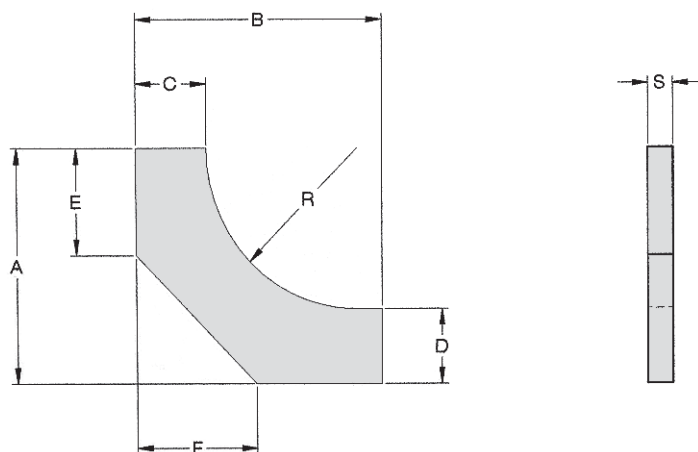

CODICE CODE	DIMENSIONI - DIMENSIONS(mm)							
	A	B	C	D	E	F	R	S
WXP - 0377	28	25	10	13	15	10	15	3-4-5
WXP - 0378	33	30	10	13	18	15	20	3-4-5
WXP - 0352	38	35	10	13	20	15	25	3-4-5
WXP - 0375	39	39	14	14	20	19	25	3-4-5
WXP - 0379	41	40	10	13	22	20	30	3-4-5
WXP - 0376	44	49	14	14	20	24	30	3-4-5
WXP - 0380	55	50	12	14	30	20	35	3-4-5

WXP - ...



FRESPURA
MILLING



LEGNO
WOOD



GREZZO
ROUGH

WH2

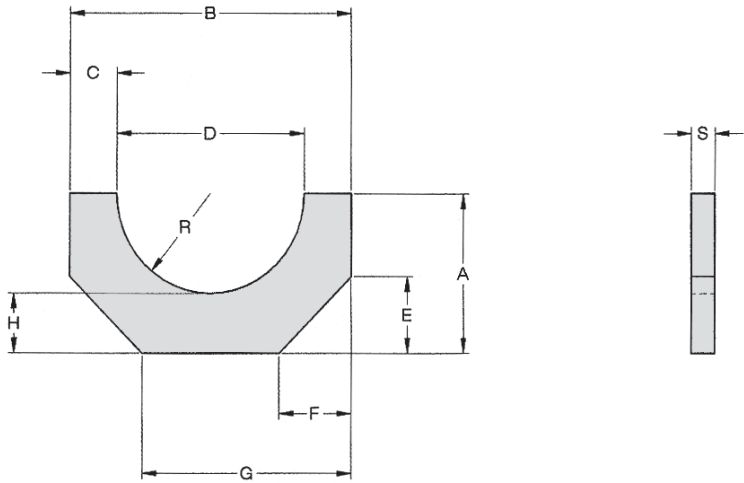

CODICE CODE	DIMENSIONI - DIMENSIONS(mm)										
	A	B	C	D	E	F	G	H	R	S	
WXP - 646	17	22	7	8	8	8	14	13	4	3-4-5	
WXP - 620	21	30	10	10	9	9	21	12	5	3-4-5	
WXP - 618	24	36	10	16	10	10	26	12	8	3-4-5	
WXP - 640	27	40	10	20	11	11	29	12	10	3-4-5	
WXP - 639	23	37	7,5	22	7,5	7,5	29,5	12	11	3-4-5	
WXP - 637	30	45	10,5	24	10	10	35	13	12	3-4-5	
WXP - 629	31	48	10	28	13,5	13,5	34,5	12	14	3-4-5	
WXP - 638	29	47	7,5	32	7,5	7,5	39,5	13	16	3-4-5	
WXP - 619	34	54	10	34	14,5	14,5	39,5	12	17	3-4-5	
WXP - 621	37	60	10	40	15,5	15,5	44,5	12	20	3-4-5	
WXP - 633	40	66	10	46	17	17	49	12	23	3-4-5	
WXP - 630	43	70	10	50	18	18	52	12	25	3-4-5	
WXP - 632	44	74	10	54	19	19	55	12	27	3-4-5	
WXP - 614	49	82	12	58	21	21	61	14	29	3-4-5	

PLACCHETTE PER LEGNO
WOOD TIPS

WXP - ...



FRESATURA
MILLING



LEGNO
WOOD



GREZZO
ROUGH



WH2

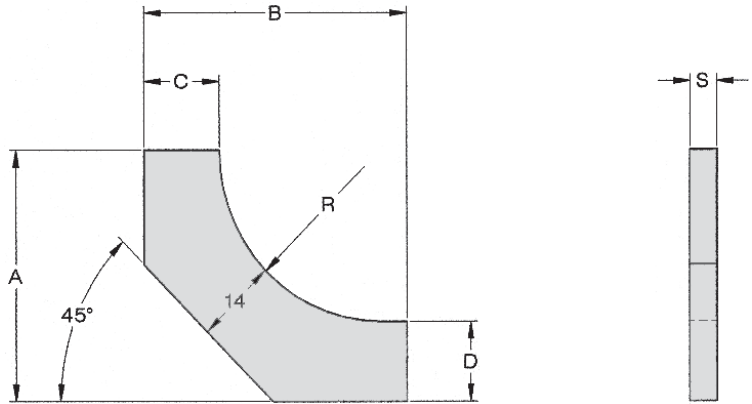

CODICE CODE	DIMENSIONI - DIMENSIONS(mm)					
	A	B	C	D	R	S
WXP - 645	21	19	10	12	5	3-4-5
WXP - 644	24	22	10	12	8	3-4-5
WXP - 615	28	25	10	12	11	3-4-5
WXP - 642	30	27	10	12	13	3-4-5
WXP - 631	31	28	10	12	14	3-4-5
WXP - 641	35	31	10	12	17	3-4-5
WXP - 636	38	34	10	12	20	3-4-5
WXP - 627	41	37	10	12	23	3-4-5
WXP - 634	44	40	10	12	26	3-4-5
WXP - 635	46	42	10	12	28	3-4-5
WXP - 617	49	46	12	12	30	3-4-5
WXP - 628	51	48	12	12	32	3-4-5
WXP - 616	56	53	12	12	37	3-4-5
WXP - 612	63	60	12	12	44	3-4-5
WXP - 649	70	66	12	12	50	3-4-5



WH2

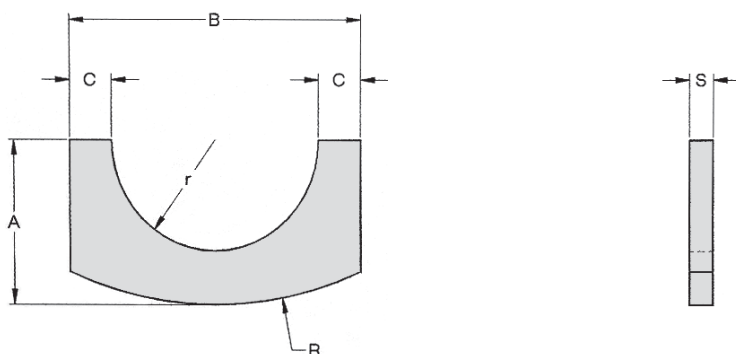

CODICE CODE	DIMENSIONI - DIMENSIONS(mm)					
	A	B	C	D	R	S
WXP - 653	7,3	16	3	5	15	3-4-5
WXP - 667	9	18	3	6	15	3-4-5
WXP - 687	11	21	3	7,5	25,4	3-4-5
WXP - 626	14	26	3	10	26	3-4-5

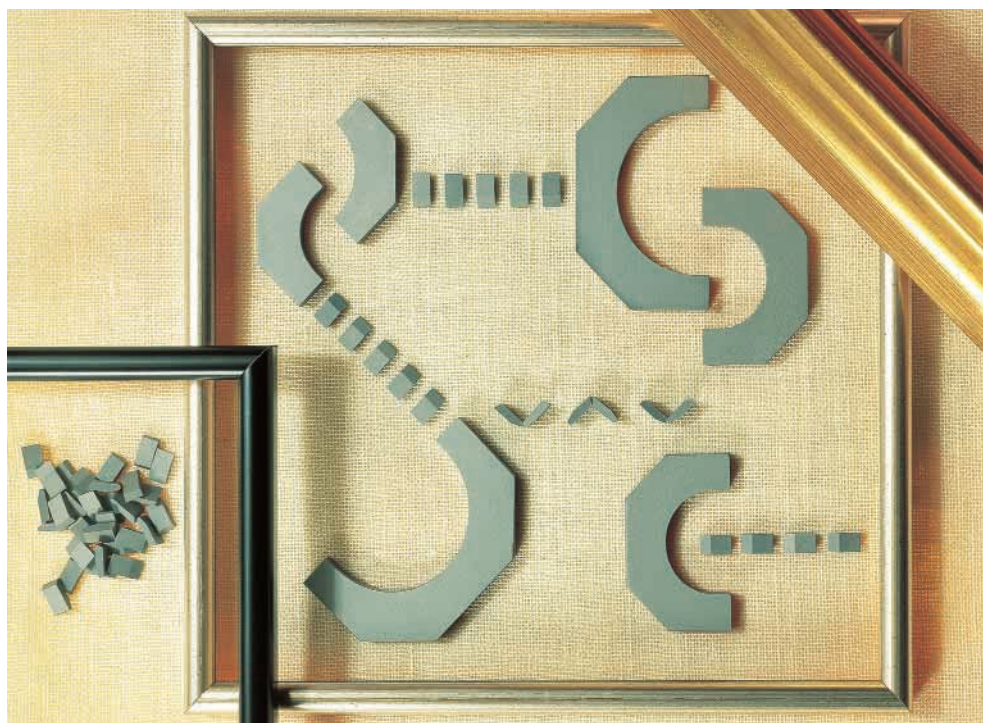

PLACCHETTE PER LEGNO
WOOD TIPS

WXP - ...



WH2

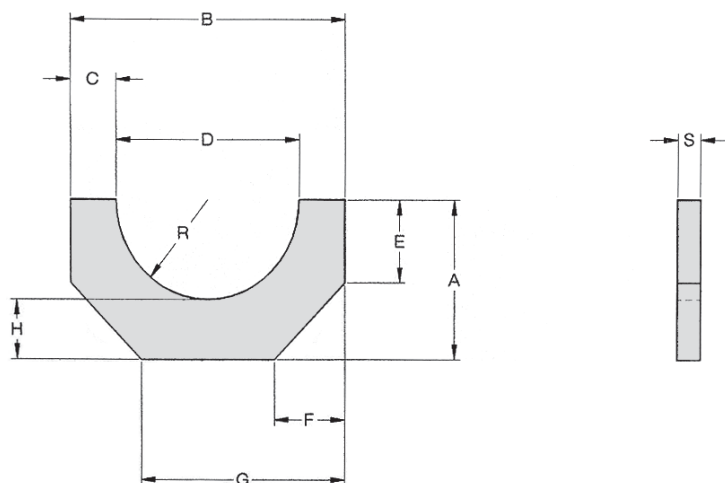

CODICE CODE	DIMENSIONI - DIMENSIONS(mm)									
	A	B	C	D	E	F	G	H	R	S
WXP - 0369	23	36	10	16	10	8	28	15	8	3-4-5
WXP - 0370	23	41	10	21	13	10	31	12,5	10,5	3-4-5
WXP - 0371	25	46	10	26	15	10	36	12	13	3-4-5
WXP - 0372	28	51	10	31	15	13	38	12,5	15,5	3-4-5
WXP - 0373	30	56	10	36	15	15	41	12	18	3-4-5
WXP - 0374	35	64	12	40	20	15	49	15	20	3-4-5

WXP - 0300/...



FRESATURA
MILLING



LEGNO
WOOD



GREZZO
ROUGH



WH2

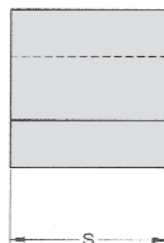
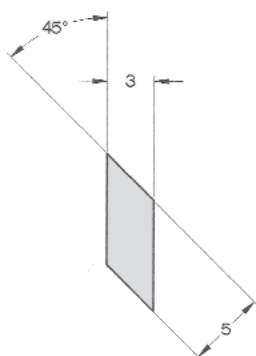

CODICE CODE	DIMENSIONI - DIMENSIONS(mm)	
	S	S. max
WXP - 0300	8,1	21,0
WXP - 1300	10,1	21,0
WXP - 2300	12,1	21,0
WXP - 3300	15,1	21,0
WXP - 4300	18,1	21,0
WXP - 5300	20,1	21,0

WXP - 0297/0265



FRESATURA
MILLING



LEGNO
WOOD



GREZZO
ROUGH



WH2

WH15

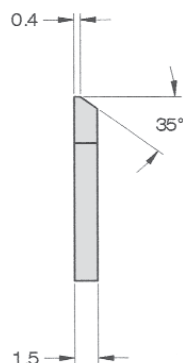
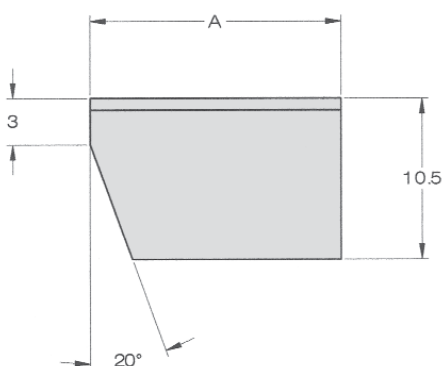

CODICE CODE	DIMENSIONI - DIMENSIONS(mm)	
	A	
WXP - 0297	11,75	
WXP - 0265	16,25	

PLACCHETTE PER LEGNO
WOOD TIPS



FRESATURA
MILLING

WH2
WH15



LEGNO
WOOD



GREZZO
ROUGH

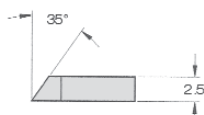
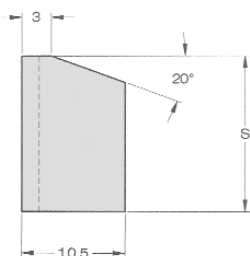

CODICE CODE	DIMENSIONI - DIMENSIONS(mm)
	S
WXP - 0119	6,50
WXP - 1119	8,00
WXP - 2119	9,00
WXP - 3119	11,75
WXP - 4119	13,75
WXP - 5119	14,00
WXP - 6119	16,00
WXP - 7119	16,25
WXP - 8119	16,40
WXP - 9119	17,00

